

FORMAX®

HERE BEGINS YOUR ULTIMATE VALUE

FS Series
Screenless Crusher

FS250



Please read the brochure carefully before operation.

■ Coding Principle

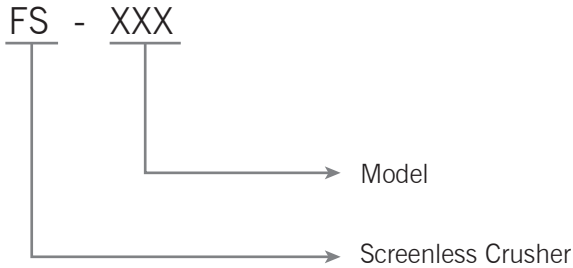

■ Features

- Adopting foreign brand of speed reducer motor, stable performance and long service life
- Adopting integrated design of the tooth cutter and the claw knife, and the coarse crushing and the fine crushing are carried out simultaneously, and the crushing is well mixed.
- The new trapezoidal tooth cutter reduces the possibility of stress concentration and increases the bearing capacity.
- Change the direction of the force, reduce the amount of force, and thus the tool life is longer
- The motor and the main shaft are connected by a coupling to make the crushing run smoothly, and it is more convenient and quick to replace the motor.
- The torque arm flange fixed speed reducer is used for stable operation and low noise.
- The motor is automatically reversed and alarmed for the resistance, and then the blocked material is automatically reset.
- Feeding hopper is made of double stainless steel to reduce noise
- The feeding box is made of transparent PC, which is convenient to view.
- Low power, high torque, slow speed, no overheating, long service life.

- The screenless is designed to smash the particles evenly and the powder content is very small. Can be mixed with new materials immediately.
- Unique design of the tool cutting not only reduce dust but also durable.

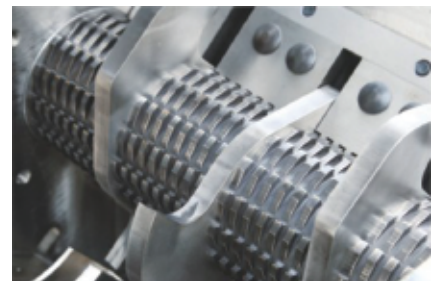

Screenless tool blade



FS Control

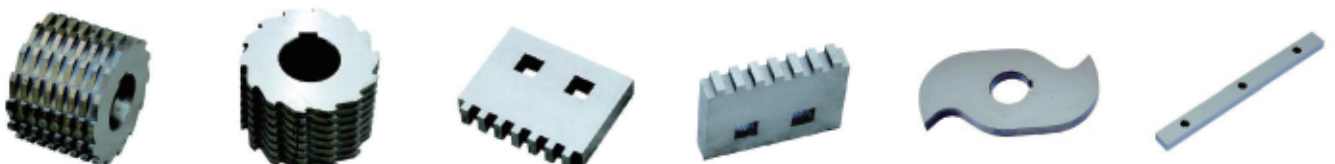

■ Application

Suitable for plastic injection molding machines and robots or with a belt conveyor to crush the regrind materials or a small amount of defective products. It has the advantages of low speed, large transmission torque, low noise, less dust and easy operation

■ Options

- The recycling system can easily return the crushed material in the box by high pressure air to the proportion valve for mixing materials and reuse, and increase the regrind materials of qualified rate of finished products.

- Optional voltage
- Number of blades
- Optional hopper

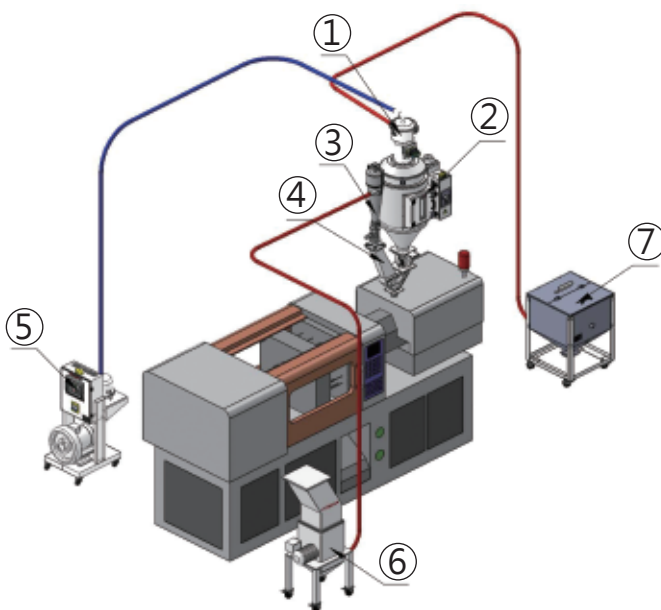

- ① Hopper Loader
- ② Hopper dryer
- ③ Cyclone separator
- ④ Proportional three socket
- ⑤ SHY Main Pump
- ⑥ Screenless Crusher
- ⑦ Material Tank

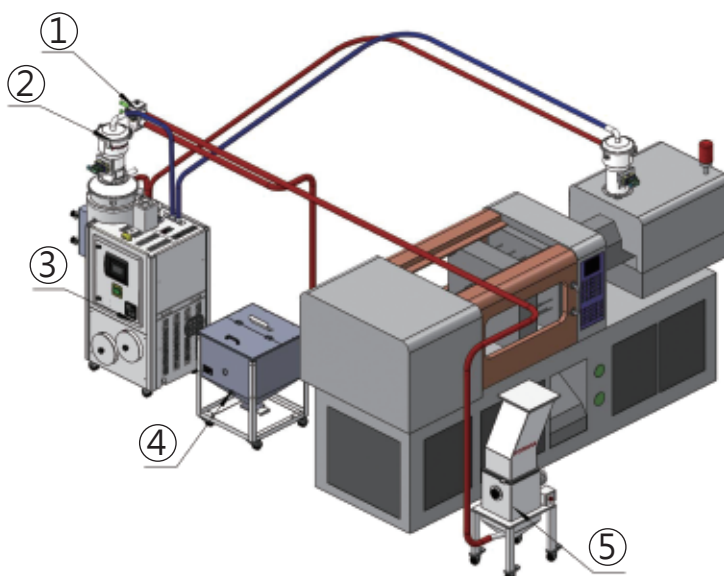

- ① Proportional valve
- ② Hopper Loader
- ③ Compact Dryers
- ④ Material Tank
- ⑤ Screenless Crusher

■ Working Principle

The crusher drives the rotary knife with high speed by the motor and go with fixed knife, using the gap between the rotary knife and the fixed knife to make an incision from crushing and shearing of regrind materials and then break the large regrind.

■ Outline Drawings

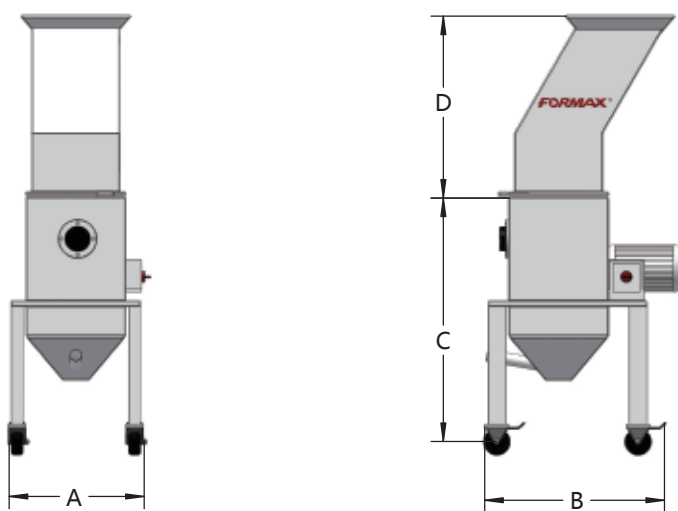

■ Specifications

Model		FS250	FS340
Drive Power	kw	1.1	1.5
Chopped Mouth	mm	252×252	252×341
Speed	rpm	32	32
Claw Knife Number		2	3
Cutter Number		3	4
Body Size	mm	1000×460×1360	1100×460×1360
Crushing Ability	kg	≥ 10	≥ 10
Weight	kg	180	220
Noise Value	db	60-73	60-75
Dimension			
Width A	mm	425	513
Length B		890	940
Height C		746	796
Height D		662	712

Specifications are subject to change without prior notice.

FORMAX®

China
Formax Plastics Automation, Inc.

Dongguan
Xianxi New Industrial Zone, Xianxi Community,
Changan Town, Dongguan, Guangdong, China
Tel. +86-769-3899-9898 Fax. +86-769-8533-3467

Kushan
No.138-20, Hengshan Road, Kunshan, Jiangsu, China
Tel. +86-512-5700-8308 Fax. +86-512-5700-8306

Taiwan
Formax Equipment Inc.

7F-1, No.265, NanKang Road, Luchu Dist.,
Taoyuan City, Taiwan
Tel. +886-3-2121-725 Fax. +886-3-2127-960

www.formax88.com
www.formaxpa.com



All rights reserved.